

MCT-OL-F 系列开环型霍尔电流传感器的初、次级之间是绝缘的，用于控制、测量直流、交流和脉冲电流。

MCT-OL-F series current sensor is an open loop device based on the measuring principle of the hall effect, with a galvanic isolation between primary and secondary circuit. It provides accurate electronic measurement of DC, AC or pulsed currents.



## 电参数 Electrical data(Ta=25°C±5°C)

型号 Type 参数 Parameter	MCT-OL-100F	MCT-OL-200F	MCT-OL-400F	MCT-OL-500F	MCT-OL-600F	MCT-OL-800F	MCT-OL-1000F	MCT-OL-2000F	单位 Unit
额定输入电流 (I <sub>pn</sub> ) Rated input (I <sub>pn</sub> )	±100	±200	±400	±500	±600	±800	±1000	±2000	A
测量电流范围 (I <sub>p</sub> ) Measure range (I <sub>p</sub> )	±300	±400	±800	±1000	±1200	±1600	±2000	±3000	A
额定输出电压 Rated output	@I <sub>p</sub> =±I <sub>pn</sub> ±4±1%								V
电源电压 Supply voltage	±15±5%								V
功耗电流 Power Consumption	+18, -10								mA
零点失调电压 Offset voltage	@I <sub>p</sub> =0 ≤15								mV
磁失调电压 Magnetic offset	@I <sub>p</sub> =±I <sub>pn</sub> ≤±30								mV
失调电压温漂 Offset drift	@ -40~+85°C ≤±0.5								mV/°C
输出电压温漂 Output drift	@ -40~+85°C ≤±0.5								mV/°C
线性度 Linearity	@I <sub>p</sub> =0-±I <sub>pn</sub> ≤1								%FS
响应时间 Response time	@50A/μ S, 10%-90% ≤5								μ S
绝缘电压 Galvanic isolation	@ 50HZ, AC, 1min 5.0								KV

## 应用 Applications

- 变频调速系统 Variable speed drives
- 电焊机 Welding machine
- 通讯电源 Battery supplied applications
- 不间断电源 Uninterruptible Power Supplies (UPS)
- 电化学 Electrochemical

## 结构参数 Mechanical dimension(for reference only)

1. All dimensions are in mm.
2. General tolerance  $\pm 1\text{mm}$ .

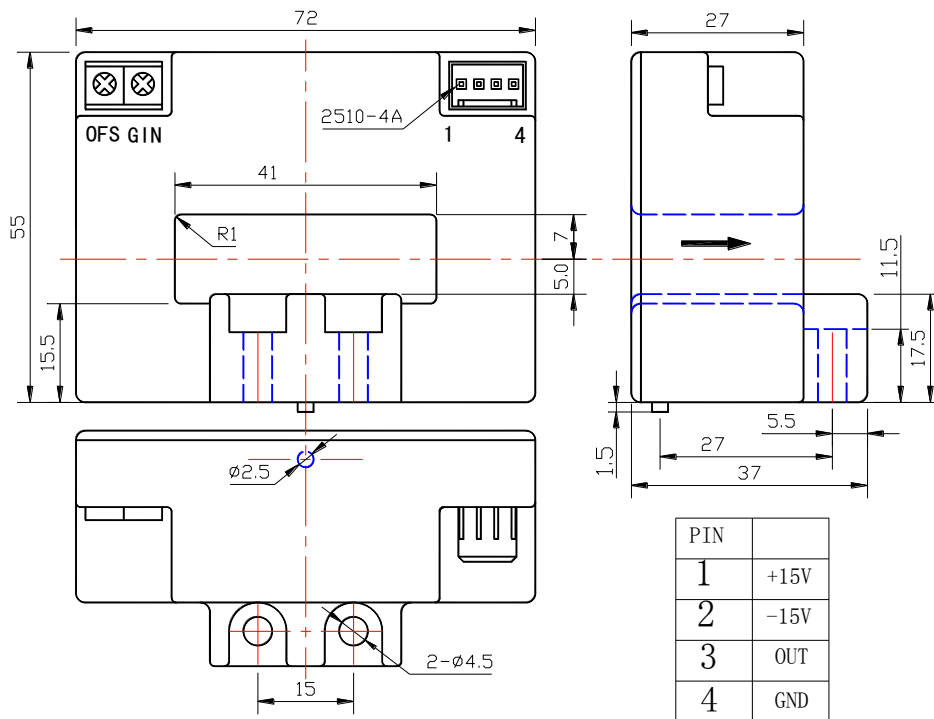

## 使用说明 Directions for use

1. 当待测电流从传感器穿过，即可在输出端测得电压大小。(注意：错误的接线可能导致传感器损坏)

When the current will be measured goes through a sensor, the voltage will be measured at the output end.

(Note: The false wiring may result in the damage of the sensor)

2. 传感器的输出幅度可根据用户需要进行适当调节。

Customs can adjust output amplitude of the sensor by needs.

3. 可按用户需求定制不同额定输入电流和输出电压的传感器。

Custom design in the different rated input current and the output voltage are available.

## 执行标准 Standards

- UL94-V0.
- EN60947-1:2004
- IEC60950-1:2001
- EN50178:1998
- SJ 20790-2000

## 总体参数 General data

	数值 Value	单位 Unit	符号 Symbol
工作温度 Operating temperature	-40 to +85	°C	TA
储存温度 Storage temperature	-40 to +125	°C	TS
毛重(约) Mass(approx)	218	g	M

输入电流-输出电压特性

Input current-Output Voltage characteristic

### MCT-OL-F Series

Primary Current ( $I_p$ )--Output (V)

