

MCT-LC-A 系列直流漏电流传感器是应用磁调制原理研制而成的一种新型电流传感器，其小电流的稳定性好，初级与次级之间高度绝缘，用于讯号系统、线路检测、漏电监测系统、电流差值测量。

MCT-LC-A series DC leakage current sensor is a kind of new device developed according to principle of electromagnetic induction. Its low current is stable. It is highly insulating between its primary coil and secondary coil. This sensor is used to measure current of signal system, circuit, and leakage monitoring system, as well as to measure current difference.



### 电参数 Electrical data(Ta=25℃±5℃)

参数 Parameter	型号 Type	MCT-LC-10A	MCT-LC-20A	MCT-LC-30A	MCT-LC-40A	MCT-LC-50A	单位 Unit
额定输入电流 (I <sub>pn</sub> ) Rated input (I <sub>pn</sub> )		10	20	30	40	50	mA
测量电流范围 (I <sub>p</sub> ) Measure range (I <sub>p</sub> )		20	40	60	80	100	mA
匝比 (N <sub>p</sub> /N <sub>s</sub> ) Turns ratio (N <sub>p</sub> /N <sub>s</sub> )		1:50	1:100	1:150	1:200	1:250	T
额定输出电压 Rated output	@I <sub>p</sub> =±I <sub>pn</sub>	±5±1%					V
电源电压 Supply voltage		±12--±15±5%					V
功耗电流 Power consumption		20+I <sub>p</sub> X(N <sub>p</sub> /N <sub>s</sub> )					mA
失调电压 Offset voltage	@I <sub>p</sub> =0	≤±50					mV
失调电压温漂 Offset voltage drift	@ -40℃~85℃	≤±1.5					mV/℃
线性度 Linearity	@I <sub>p</sub> =0-±I <sub>pn</sub>	≤1					%FS
响应时间 Response time		≤50					mS
绝缘电压 Galvanic isolation	@ 50Hz, AC, 1min	2.5					KV

## 应用 Applications

- 变频调速系统 Variable speed drives
- 电焊机 Welding machine
- 通讯电源 Battery supplied applications
- 不间断电源 Uninterruptible Power Supplies (UPS)
- 电化学 Electrochemical

## 结构参数 Mechanical dimension(for reference only)

1. All dimensions are in mm.
2. General tolerance  $\pm 1\text{mm}$ .

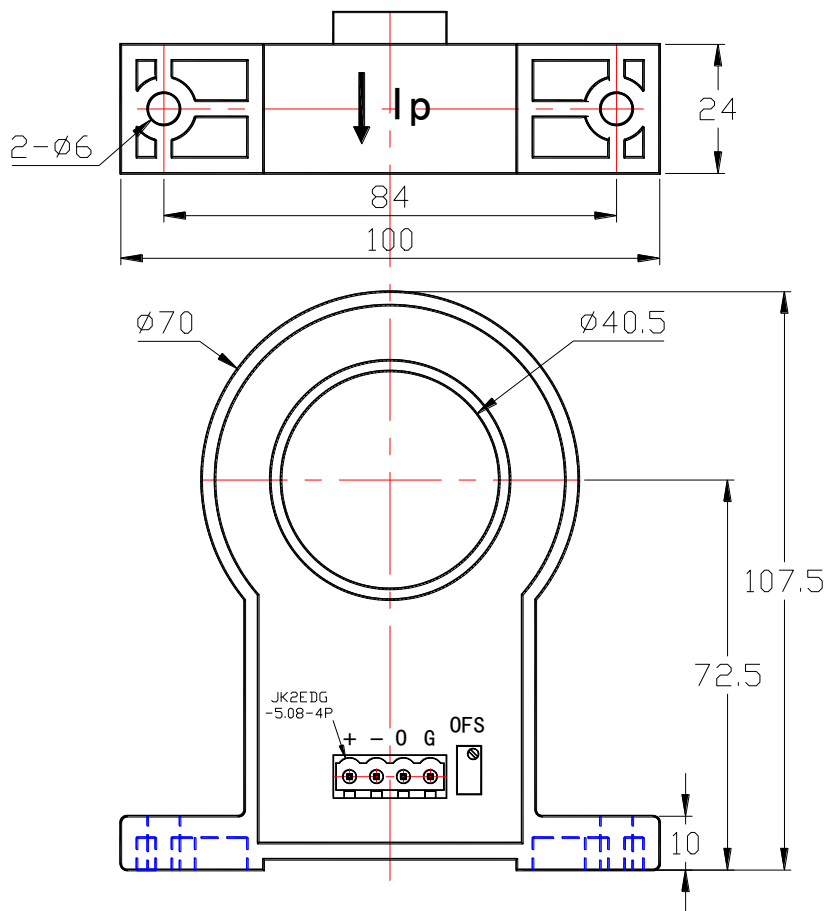

Pins	Connected
1	+15V
2	-15V
3	OUT
4	GND

## 使用说明 Directions for use

1. 当待测电流从传感器穿过，即可在输出端测得电压大小。(注意：错误的接线可能导致传感器损坏)

When the current will be measured goes through a sensor, the voltage will be measured at the output end.

(Note: The false wiring may result in the damage of the sensor)

2. 传感器的输出幅度可根据用户需要进行适当调节。

Customs can adjust output amplitude of the sensor by needs.

3. 可按用户需求定制不同额定输入电流和输出电压的传感器。

Custom design in the different rated input current and the output voltage are available.

## 执行标准 Standards

- UL94-V0.
- EN60947-1:2004
- IEC60950-1:2001
- EN50178:1998
- SJ 20790-2000

## 总体参数 General data

	数值 Value	单位 Unit	符号 Symbol
工作温度 Operating temperature	-40 to +85	°C	TA
储存温度 Storage temperature	-40 to +125	°C	TS
毛重(约) Mass(approx)	251	g	M

输入电流-输出电压特性  
 Input Current-Output Voltage

### MCT-LC-A Series

Primary Current ( $I_p$ ) -- Output (V)

