

Printed-Circuit-Board transformers

Output Power: 130.0 VA – 200.0 VA

Private customized version

Custom-made models are available on request, e.g. with or without mounting brackets, other heights, pin configurations or connections.

Frame size/Core height	Output Power Ta 70° C	Height(h)	Weight
MCT EI 961/35.7mm	130.0V/A	60.2 ± 0.5mm	2.600kg
MCT EI 962/46.5mm	160.0 V/A	70.0 ± 0.5mm	3.800kg
MCT EI 963/59.7mm	200.0V/A	84.0 ± 0.5mm	4.600kg

Type cast housing "B" with 16 connection pins

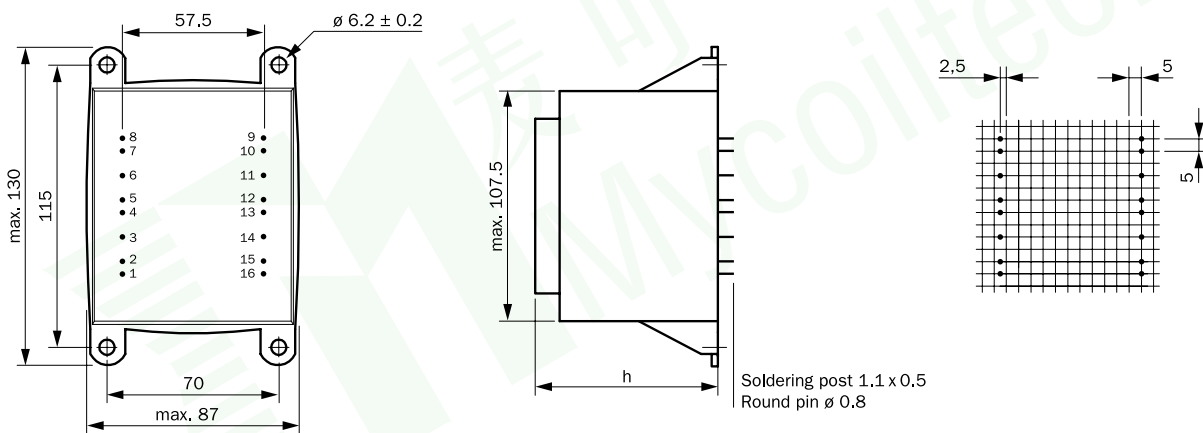

View looking onto pins

Soldering post 1.1 x 0.5
Round pin ø 0.8

Dimensions without tolerances ± 0.3 mm,
rights to make alterations and improvements hereby reserved

Type cast housing "B" with 20 connection pins

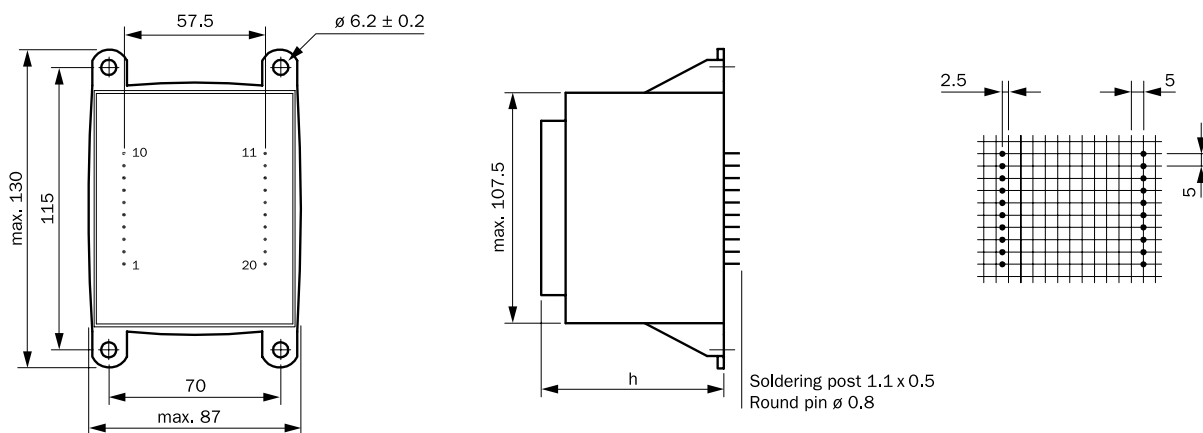

View looking onto pins

Soldering post 1.1 x 0.5
Round pin ø 0.8

Dimensions without tolerances ± 0.3 mm,
rights to make alterations and improvements hereby reserved

Printed-Circuit-Board transformers

Output Power: 130.0 VA – 200.0 VA

Type cast housing "B" with 24 connection pin

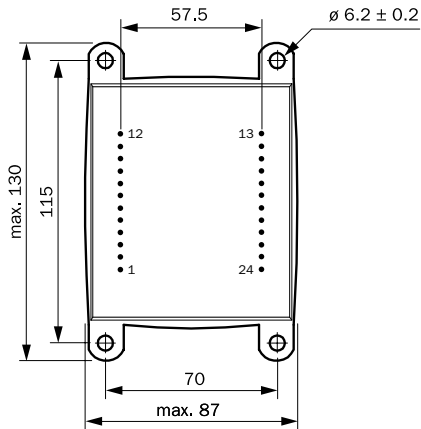

View looking onto pins

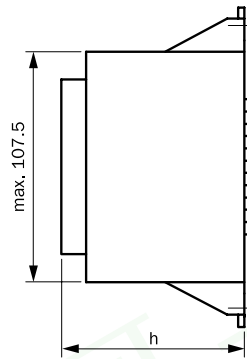

Soldering post 1.1 x 0.5
Round pin \varnothing 0.8

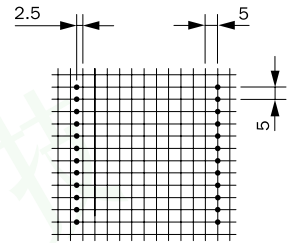

Dimensions without tolerances \pm 0.3 mm,
rights to make alterations and improvements hereby reserved

Type cast housing "B" with 32 connection pins

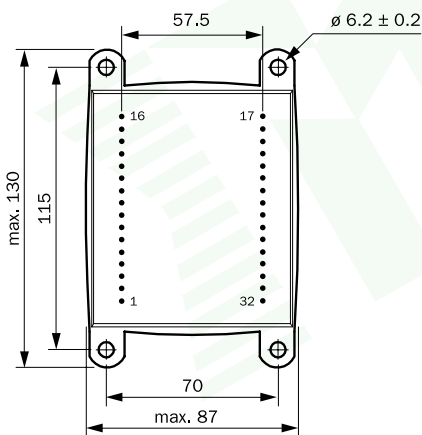

View looking onto pins

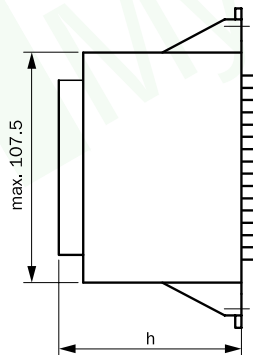

Soldering post 1.1 x 0.5
Round pin \varnothing 0.8

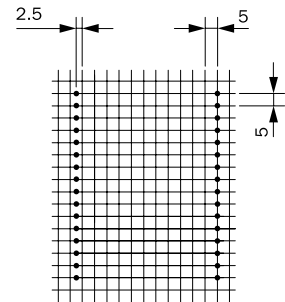

Dimensions without tolerances \pm 0.3 mm,
rights to make alterations and improvements hereby reserved

Type cast housing "C" for upright mounting

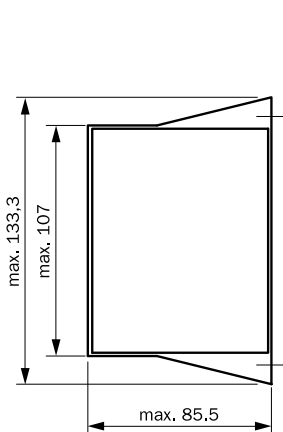

View looking onto pins

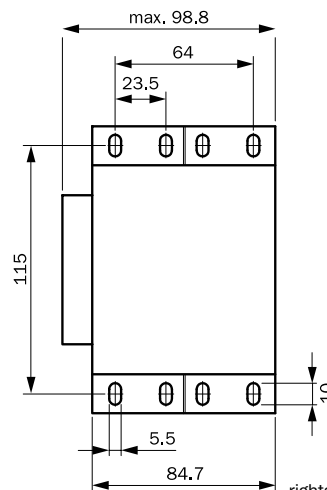

Dimensions without tolerances \pm 0.3 mm,
rights to make alterations and improvements hereby reserved